

Definition Packet

Modular Framing Systems, Inc.

P.O. BOX 40794 * HOUSTON, TEXAS ** 77240 ** TEL 713-983-7999 * FAX 713-983-8488

Modular Framing Systems, Inc.

What is an Aluminum Modular Frame?

Using this system, an Aluminum Modular Frame is a three (3) dimensional rectangular structure that is assembled using the four (4) basic components described below.

The basic components are:

1. Extruded Aluminum Profile
2. Corner Joints to connect the Profiles
3. Extruded Aluminum Omega
4. Omega Joints (GOP's)

Item 1 – Extruded Aluminum Profile

The Profile is an aluminum extrusion that is used to form the outer skeleton of a structure. The profile can be cut to any measurement to adjust the length, width, and, height of your product. For any given rectangular object, there are twelve (12) pieces taken from the aluminum profile; four (4) for the length, four (4) for the width, and four (4) for the height, as indicated by the colored portion in the figure below.

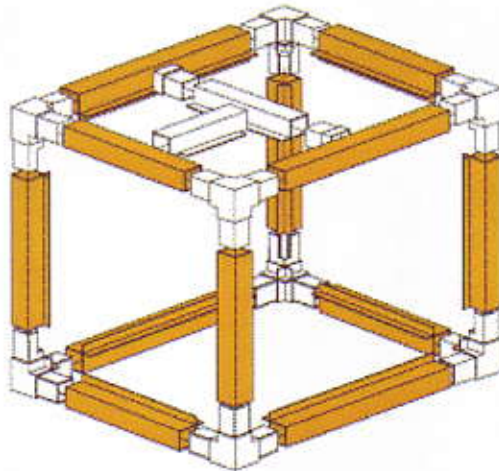

Below are examples of six (6) different styles of extruded aluminum Profiles. Our extruded profile is designed to accommodate a nominal one (1) inch or two (2) inch panel thickness. We stock these extrusions in twenty (20) foot lengths. This allows customers to cut the aluminum to their desired measurements. A chop saw with a non-ferrous blade is needed to cut the aluminum.

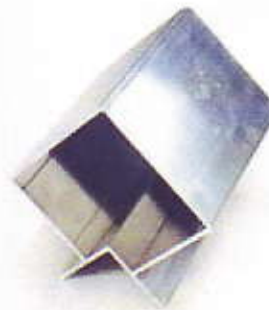
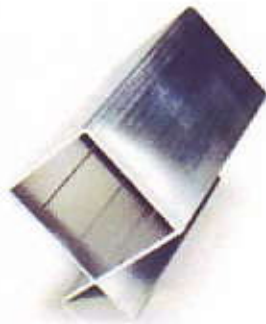
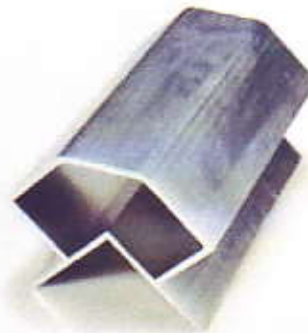
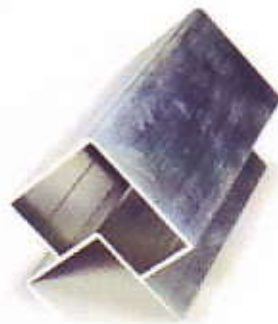

Item 2 – Corner Joints for the Profile

The Corner joints are a pressure die cast aluminum component designed to insert into a piece of profile utilizing a slight interference fit. Eight (8) Corner joints are needed to connect the twelve (12) Profile pieces mentioned under Item One (1). Sheet metal screws, rivets, or epoxy can be used to secure the Profile to the Corners. Refer to the picture below.

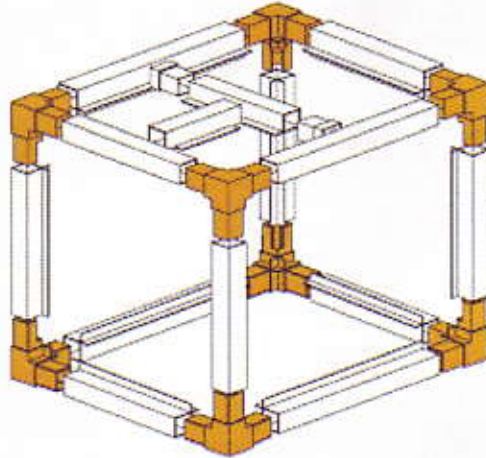

We stock die cast aluminum and nylon fiberglass (bottom right) corners in various sizes. Below are pictures of four (4) different Corner joints.



Item 3 – Extruded Aluminum Omega

The Omega is an aluminum extrusion that is generally used in two (2) ways. First, it can be used as an intermediate, vertical and/or horizontal, support between two (2) pieces of profile. By doing this, you add strength and rigidity to the structure. Second, it can be used to frame openings such as access doors for coils, filters, and fans, as well as openings for fan discharge areas. The Omega is shown in color below. Please note that this component can be placed anywhere on the structure between two (2) pieces of Profile or between other Omega's.

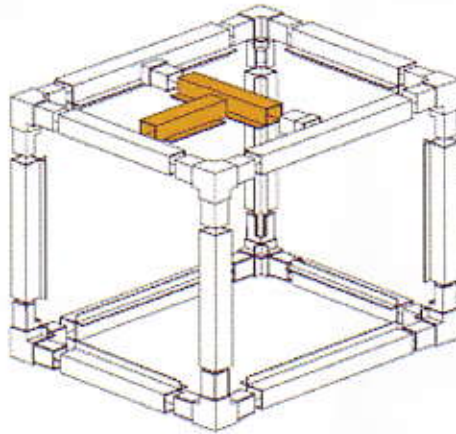

Below are four (4) examples of our Omegas. These are also stocked in twenty (20) foot lengths and are designed to accommodate a nominal one (1) inch or two (2) inch panel thickness.

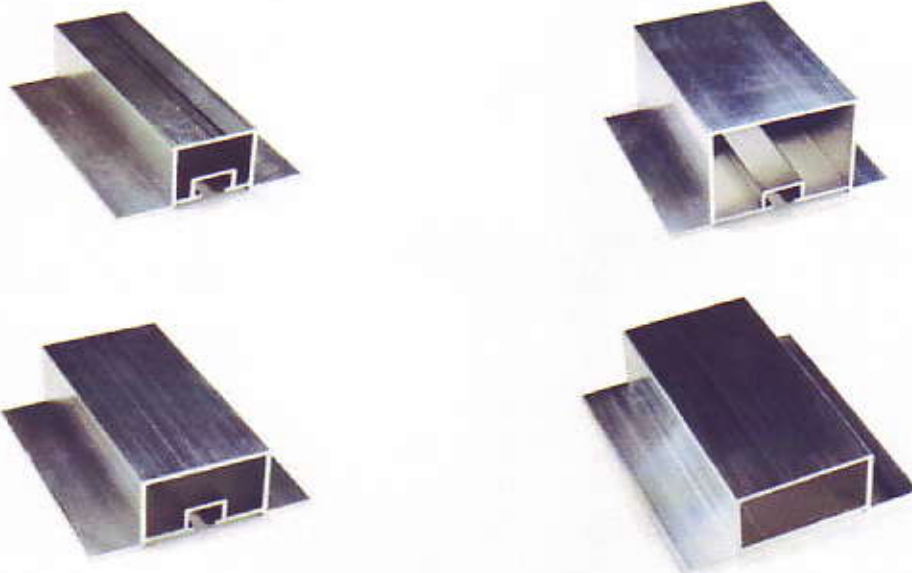

Item 4 – Omega Joints (GOP's)

The Omega joints, or as we call them GOP's, insert into both ends of each piece of the Omega utilizing a slight interference fit.



The GOP's are used to attach the Omegas to the flange of the Profile. Refer to the picture below.

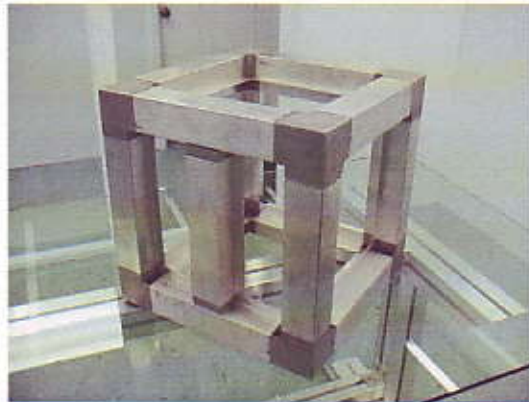

A self-drilling sheet metal screw is typically used to secure the GOP/Omega member the Profile flange.

What Can I Do With The Aluminum Modular Frame?

For Custom Air Handling Unit Manufacturing and Retrofit Work:

The Aluminum Modular Framing System offers quick, easy, and accurate assembly for virtually any type of air handling unit. Our system eliminates the need for welding, and allows for easy customization. There is no large capital investment for tooling. All that is required for the cutting and assembly of the material is a standard chop saw with a carbide blade, a drill, and a rubber mallet. This is extremely beneficial to those in the custom manufacturing and retrofit business because on-site work is a feasible option.

For Sheet Metal Contractors:

The system gives a sturdy, square structure to build various types of enclosures, plenums, or cabinets. Sheet metal contractors that get involved with large custom rectangular ductwork can fabricate their products in long sections and hang them easily. Threaded rods can be installed through pre-drilled holes in the Corner joints, allowing the plenum/duct to be self-supporting. (No trapeze hangers are required.)

